

Warrior X Turbo

Thank you for purchasing this Olight Product. Please read this manual carefully before use and keep it for future reference!

IN THE BOX

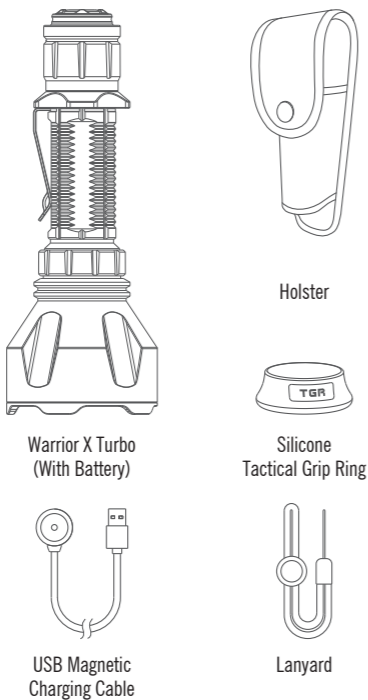

SPECIFICATIONS

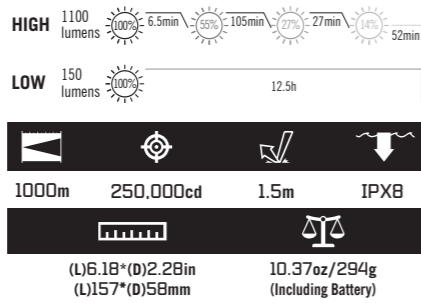

All above specifications are test results based on ANSI/NEMA FL1-2009 Standard. The tests are performed using the battery included in the flashlight.
Note: The maximum output brightness will decrease as the battery voltage decreases.

USB MAGNETIC CHARGING CABLE -- MCC3

Parameter	Specification
Charging cable	USB Type A - magnetic charging connector, length: 0.5m
Input	USB A - Type DC 5V 2A
Charging pattern	CC&CV
Maximum charging current	2A
Full-capacity charging voltage	4.2V±0.05V
Charge indication	Red: charging Green: full (over 95%) or disconnected with flashlight
Time to fully charge	5.5 hours (For reference only. When the USB power source is insufficient to provide 5V 2A power capacity, the charging time will be longer)

PRODUCT OVERVIEW

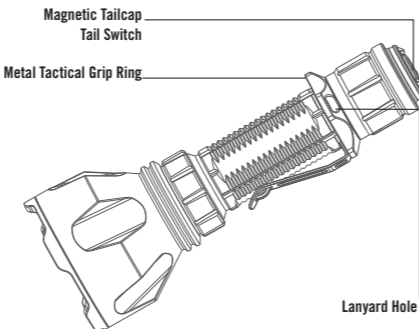

BEFORE FIRST USE

Before first use, please remove the protective film on the lens; and please also unscrew the tailcap to remove the insulating film within the battery compartment, then screw the tailcap back on tightly. If the battery needs to be changed, make sure that the positive polarity side of the battery faces the flashlight head (the side of the LED).

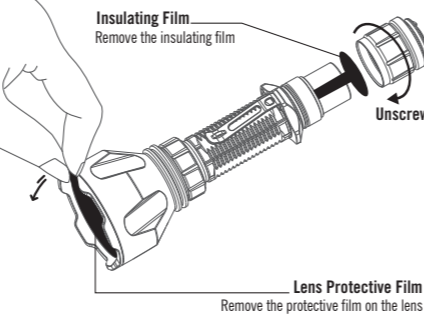

CHARGING

Vibrating Power Indicator

It helps to alert if the battery is low (power <20% vibrate once every 5 minutes; power <10% vibrate once per minute; power <5% vibrate once every 10 seconds).

GREEN

Charging Completed

RED

Charging

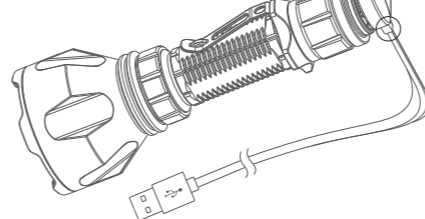

* Before first use please fully charge the product.

* Connect the USB Type-A end of the magnetic charging cable (MCC3) to an external USB power source, then attach the magnetic end to the magnetic charging port of the flashlight (best charging efficiency with a 10W (5V 2A) USB power source). The red indicator means charging, while the green indicator means charging completed (battery level > 95%).

* Only to charge with standard MCC3. NOT compatible with other MCC.

Tactical Grip Ring (TGR) Replacement Guide

a. Unscrew the tailcap and remove the O-ring.

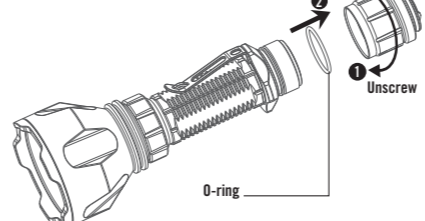

b. Then remove the metal TGR and pocket clip.

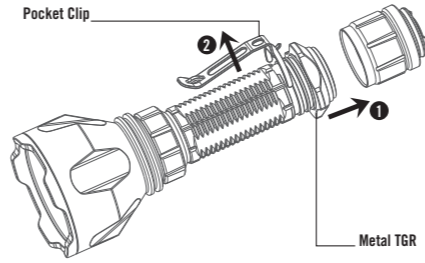

C. Install the silicone TGR and O-ring as shown in the picture and tighten the tailcap.

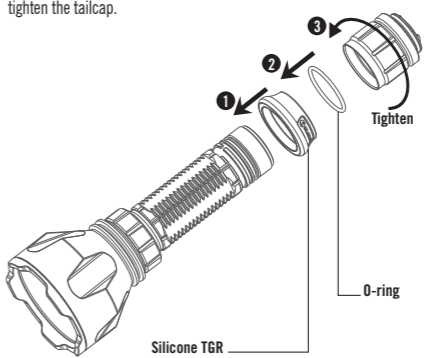

DANGER

- DO NOT throw the light directly into human eyes. This may cause temporary blindness, or permanent damage to the eyes.
- DO NOT cover the flashlight's head or stand the flashlight on its head when it is on. The radiation energy may cause damage to the flashlight itself, or even result in the burning of flammable objects nearby.
- DO NOT use non-protected rechargeable batteries.

WARNING

- Keep out of reach of children.
- DO NOT activate high mode repeatedly under high temperature to prevent the flashlight body from overheating and hurting the user's hand.
- The tail switch may not work while immersed in seawater or other conductive media. Please try to keep it clean and dry.
- If the product is left unused or carried and transported, please loosen the tailcap a half turn to avoid accidentally activating the flashlight.

NOTICE

- DO NOT short-circuit the switch cap with the ring surrounding it. The short circuit in this case will result in an electric discharge of below 6mA between them, and may lead to a complete battery drain if it is in this state for too long.

CONTENTS

(EN) English 01

(CHS) 简体中文 01

(FI) Finnish 01

(NO) Norwegian 01

(SV) Swedish 01

(NED) Nederland 01

(PL) Polska 02

(DE) Deutsch 02

(HU) Magyarország 02

(RU) Русский 02

(ES) Español 02

(RO) Romanesc 03

(UA) Ukrainian 03

(JP) 日本語 03

(TH) ไทย 03

(FR) Français 03

(BG) Български 03

(IT) Italia 04

(SK) Slovenský jazyk 04

(EN) English

HOW TO OPERATE

Click the tail switch lightly to produce a low light output or press the tail switch hard to produce a high light output.
Single click (click and release quickly) the tail switch to turn the flashlight on or off.
When you press and hold the switch, the flashlight will be in momentary mode; when you release the tail switch, it will turn off.

(CHS) 简体中文

如何操作手电
轻按输出低亮档，重按输出高亮档；
单按（按下并快速释放）开启或关闭手电；
长按并保持，手电开启，按键释放时手电同步关闭。

(FI) Finnish

VALAISIMEN KÄYTTÖ
Käytä alhaista valotehoa painamalla kytkintä kevyesti ja korkeaa valotehoa painamalla kytkintä kovaa.
Kytke valaisin päälle ja pois päältä painamalla kytkintä kerran lyhyesti.
Käytä valaisinta hetkellisesti pitämällä kytkintä käytön ajan painettuna.
Valo sammuu kun kytkin vapautetaan.

(NO) Norwegian

HVORDAN BRUKE
Klikk lett på bryteren for å produsere et svakt lys, eller trykk hardt på bryteren for høy lyseffekt.
Enkelt klikk (klikk og slipp raskt) på bryteren for å slå lommelykten av eller på.
Når du trykker og holder inne bryteren, vil lommelykten være i øyeblikkelig modus, når du slipper bryteren, vil den slå seg av.

(SV) Swedish

BYTA EFFEKTLÄGE
Klicka på knappen lätt och lampan kommer lysa med svag styrka eller klicka på knappen hårt för att lampan ska lysa med hög ljusstyrka.
Klicka en gång (tryck släpp snabbt) på knappen för att tända/släcka lampan.
När du klickar och håller ned knappen, kommer lampan tändas momentant, när du släpper knappen, slöcknar lampan.

(NED) Nederland

HOE TE BEDIENEN
Klik zachtjes op de staartschakelaar om een laag lichtrendement te produceren of druk hard op de staartschakelaar om een hoog lichtrendement te produceren.
Eén keer klikken (snel klikken en loslaten) op de staartschakelaar om de zaklamp in of uit te schakelen.

Als u de schakelaar ingedrukt houdt, bevindt de zaklamp zich in tijdelijke modus; als u de staartschakelaar loslaat, wordt deze uitgeschakeld.

(PL) Polska

INSTRUKCJA UŻYTKOWANIA:
lekkie wciśnięcie tylnego przycisku spowoduje uruchomienie latarki w trybie najniższym. Mocne wciśnięcie tylnego przycisku spowoduje włączenie trybu najwyższego.
Pojedyncze wciśnięcie tylnego przycisku spowoduje włączenie lub wyłączenie latarki.
Wciśnięcie i przytrzymanie tylnego przycisku spowoduje chwilowe włączenie, puszczenie przycisku wyłączy latarkę.

(DE) Deutsch

BEDIENUNG
Durch leichtes Drücken des Endkappenschalters erhält man eine niedrige Lichtleistung, durch festeres Drücken des Endkappenschalters erhält man eine hohe Lichtleistung.
Durch einmaliges Drücken des Endkappenschalters (schnelles Klicken und Loslassen) wird die Taschenlampe an- oder ausgeschaltet.
Wenn Sie den Endkappenschalter gedrückt halten, leuchtet die Taschenlampe im Momentary Modus; Wenn Sie den Endkappenschalter loslassen, wird die Taschenlampe ausgeschaltet.

(HU) Magyarorszá

A HASZNÁLAT MÓDJA
Nyomja meg finoman a hátsó zárókupakon lévő kapcsolót az alacsony fényerőfokozat üzemmód kapcsolásához. A lámpa erős fényerőfokozatra kapcsolásához nyomja be teljesen a hátsó zárókupakon lévő kapcsolót.
A hátsó zárókupakon lévő kapcsoló gyors teljes benyomásával és felengedésével a lámpa bekapcsolható, illetve kikapcsolható.
A kapcsoló benyomásának és nyomva tartásának idejére a lámpa bekapcsol, majd a kapcsoló felengedésekor kikapcsol.

(RU) Русский

Инструкция
Легкое нажатие активирует режим 150 люмен, полное нажатие активирует режим 1100 люмен.
Для вкл/выкл фонаря необходимо быстро нажать и отпустить торцевую кнопку.
Если нажать и удерживать кнопку, фонарь будет гореть до тех пор, пока Вы ее не отпустите.

(ES) Español

CÓMO OPERAR
Pulse suavemente el interruptor remoto para producir poca luz de salida o pulse fuerte el interruptor remoto para producir mucha luz de salida.
Un Sólo Clic (pulse brevemente) el interruptor remoto para encender o apagar la linterna.
Cuando mantiene pulsado el interruptor, la linterna estará en modo momentáneo; Cuando suelta el interruptor remoto, se apaga.

(RO) Romanesc

MOD DE OPERARE:
Apasati butonul usor pentru a porni in modul mic sau apasati butonul ferm (tare) pentru a porni modul maxim.
Apasare normala (apasati scurt apoi eliberati) pentru a porni sau opri lanterna.
Atunci cand apasati si mentineti apasat butonul, lanterna va intra in mod iluminare momentan; a eliberarea butonului din spate lanterna se va stinge.

(UA) Ukrainian

Як працює:
Легке натискання на торцеву кнопку вмикє економіний режим яскравості; сильніше натискання переводить ліхтарик у стандартний режим світіння.
Одне швидке натискання кнопки (натисніть і одразу відпустіть) вмикє і вимикє ліхтарик.
Якщо натиснути і так утримувати кнопку, ліхтарик світитиме, і вимкнеться, якщо кнопку відпустити.

(JP) 日本語

使用方法
テールスイッチを軽く押すとLowモードで常時点灯。強く押すとHighモードで点灯します。
テールスイッチをシングルクリック（クリックして素早く離す）するとライトが点灯・消灯します。
テールスイッチを長押しすと（指はスイッチから離さないまま）ライトが点灯します、スイッチを離すと消灯します。

(TH) ไทย

ไฟฉาย Warrior X Turbo มีโหมดต่าง ๆ อยู่หลายโหมดซึ่งสามารถกำหนดได้โดยการกดสวิทช์ท้ายเช่นนี้หรือเบาสำหรับการเปิดไฟฉาย ทำให้โดยการกดสวิทช์ท้ายแล้วปล่อย ไฟฉายจะเปิดทำอีกครึ่งเพื่อปิดไฟฉาย ส่วนการเปิดหรือปิดชั่วคราว ได้โดยการกดสวิทช์ท้ายครึ่งนี้ค้างไว้ ไฟฉายจะติดและไฟฉายจะดับเมื่อปล่อยสวิทช์ท้าย

(FR) Français

COMMENT L'UTILISER
Presser légèrement le bouton arrière pour activer le niveau de sortie faible ou presser plus fort pour activer le mode fort.
Un simple clic (presser et relâcher rapidement) allume et éteint la lampe.
Lorsque vous pressez et maintenez le bouton, la lampe s'active momentanément ; lorsque vous relâchez le bouton la lampe s'éteint.

(BG) Български

Начин на работа
Леко задействане на бутон а за слаб режим и пълно задействане за силен режим.
Единичен бърз клик – включване/изключване.
Задействане и задържане на бутон а за моментно

задействане. При отпускане на бутон а фенера се изключва.

(IT) Italia

FUNZIONAMENTO
Premere leggermente l'interruttore posteriore per produrre un'emissione di luce bassa o premere con forza l'interruttore posteriore per produrre un'elevata emissione di luce.
Con un solo clic (fare clic e rilasciare rapidamente) l'interruttore posteriore per accendere o spegnere la torcia elettrica.
Quando si tiene premuto l'interruttore, la torcia si trova in modalità momentanea; quando si rilascia l'interruttore, si spegne.

(SK) Slovenský jazyk

AKO POUŽÍVAŤ
Laško stlačte spínač koncovky, aby ste dosiahli slabý svetelný výkon, alebo stlačte silnejšie koncový spínač, aby ste dosiahli vysoký svetelný výkon.
Jedným kliknutím (rychlým kliknutím a uvoľnením) koncovým spínačom zapnete alebo vypnete svetidlo.
Keď stlačíte a podržíte spínač, svetidlo bude vo chvíľkovom režime; pri uvoľnení koncového spínača sa vypne.

EU-DECLARATION OF CONFORMITY



EU-Declaration of Conformity can be found here: <https://olightworld.com/ec-declaration>

WARRANTY

Within 30 days of purchase: Contact the original seller for repair or replacement.
Within 5 years of purchase: Contact Olight for repair or replacement.
Battery warranty: Olight offers a one year warranty for all rechargeable batteries.
MCC magnetic USB charging cable: One year.

For any of the fragile or low-value fittings not covered above, like lanyard and clip, you can contact the post-sale in 30 days after the purchase, if it has any quality drawback or damage under normal use condition. If such drawback or damage occurs 30 days after the purchase or under abnormal use condition, we will only offer conditional quality assurance as appropriate.

USA Customer Support

cs@olightstore.com

Global Customer Support

customer-service@olightworld.com

Visit www.olightworld.com to see our complete product line of portable illumination tools.

